



DITEC Door Frame Systems



DITEC Door Frame Systems

▶ DITEC PAM

Door frame systems specifically designed to better meet automatic pedestrian door requirements.

The wide range of solutions available allows DITEC door frames to fit perfectly any architectural setting by providing a smart and unobtrusive door frame, which conforms to the stringent standards.

Comfort, safety, high quality, transit and air conditioning control are the key benefits offered by DITEC doors.

- ▶ The door frames are available in the most diverse range of configurations and colours to ensure the customer the most suitable solution:

PAM 16 with very thin surrounds to make the glass a more prominent feature;

PAM 30 with average strength frames but featuring reduced size visible sections;

PAM 35 for practical, strong, intensive use and/or multifunction, very well designed and shaped doors.

- ▶ The frames can be supplied with emergency devices. By simply pushing the doors, these devices allow the breakout opening device to activate immediately, without causing any damage to the door and promptly restoring all door functions.

- ▶ Suitable for applications such as emergency exits (TÜV certified):

ASMI/ASME breakout of sliding panels only (1 or 2 panels);

AST full breakout of sliding panels and partly fixed side panels (central or side opening).

- ▶ In order to optimise the use of space and to widen the transit opening, all PAM series products are fitted with a telescopic opening device.

- ▶ To create DITEC entrances, 3 different product lines are available:

1) Door frame components: profiles (rough or natural anodised), accessories and seals, supplied with manuals and technical specifications to allow the customer to create DITEC entrances from start to finish: preparation, assembly and fitting.

2) Frame kits: made to measure in the colour selected by the customer and complete with all components and assembly and fitting instructions (excluding the glass panels).

3) Pre-assembled frames: made to measure, supplied in the colour selected by the customer, assembled and complete with all components and fitting instructions (excluding glass panels).

- ▶ **DITEC = PEACE OF MIND**

Experience in research and development, production, design, installation and geographical coverage are just a few of DITEC strengths, which are coupled with a reliable post-sale customer service.

▶ Examples of types available

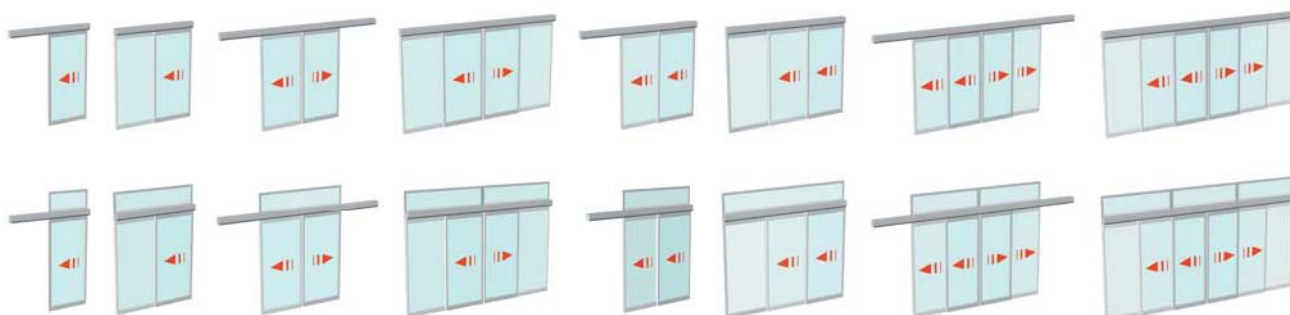

DITEC: a comprehensive range

Layout

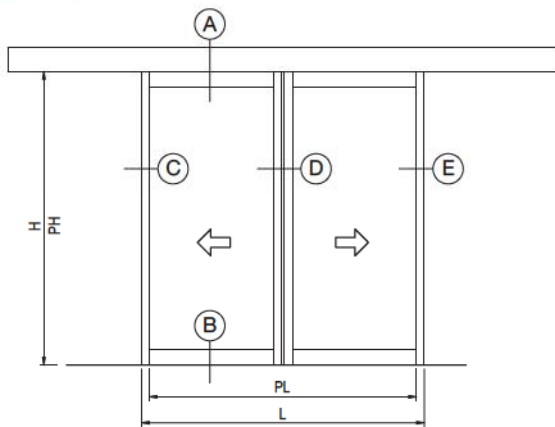

Vertical sections

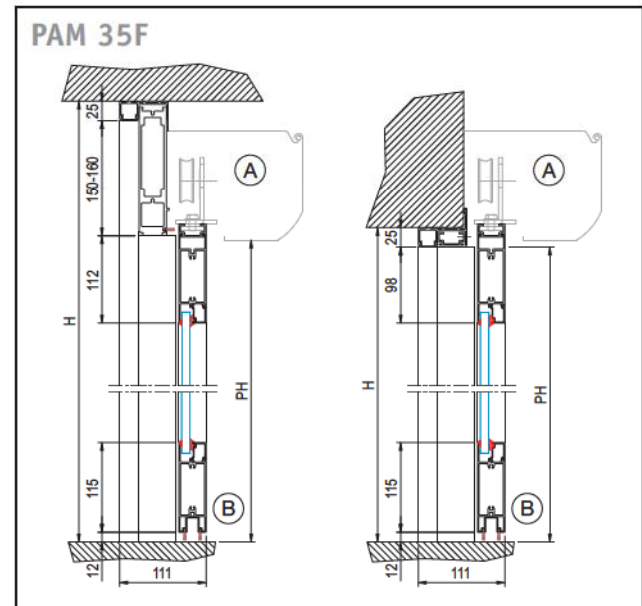

Horizontal sections

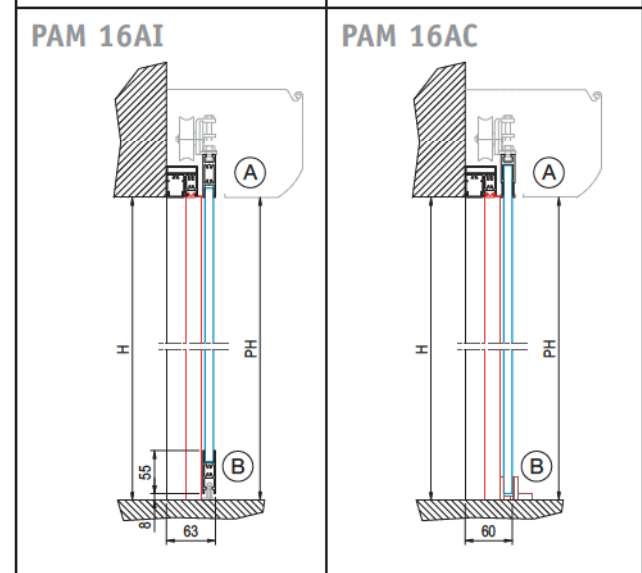
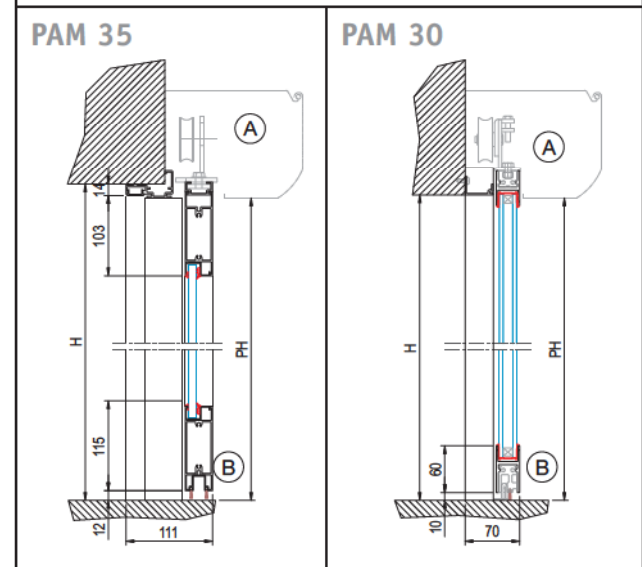
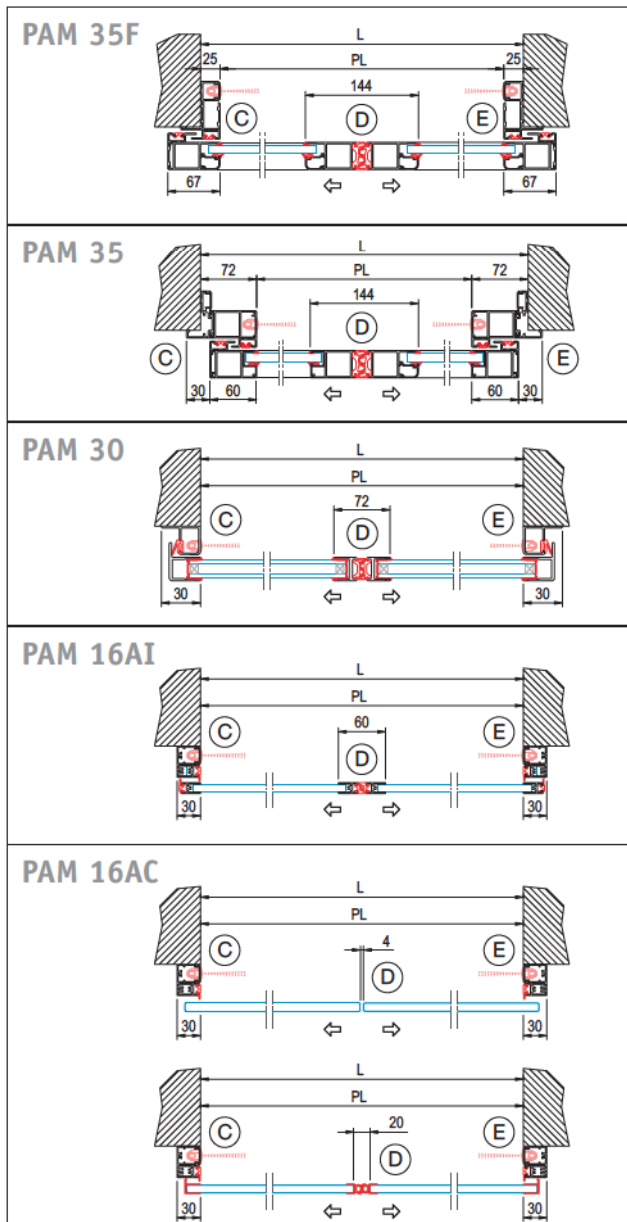

Solutions for straight sliding door frames

Horizontal sections

<p>Sliding openings Examples of types available</p>	<p>PAM 35F Overhead clearances</p>
	<p>PAM 35F</p>
	<p>PAM 30</p>
	<p>PAM 16AI</p>



Vertical sections

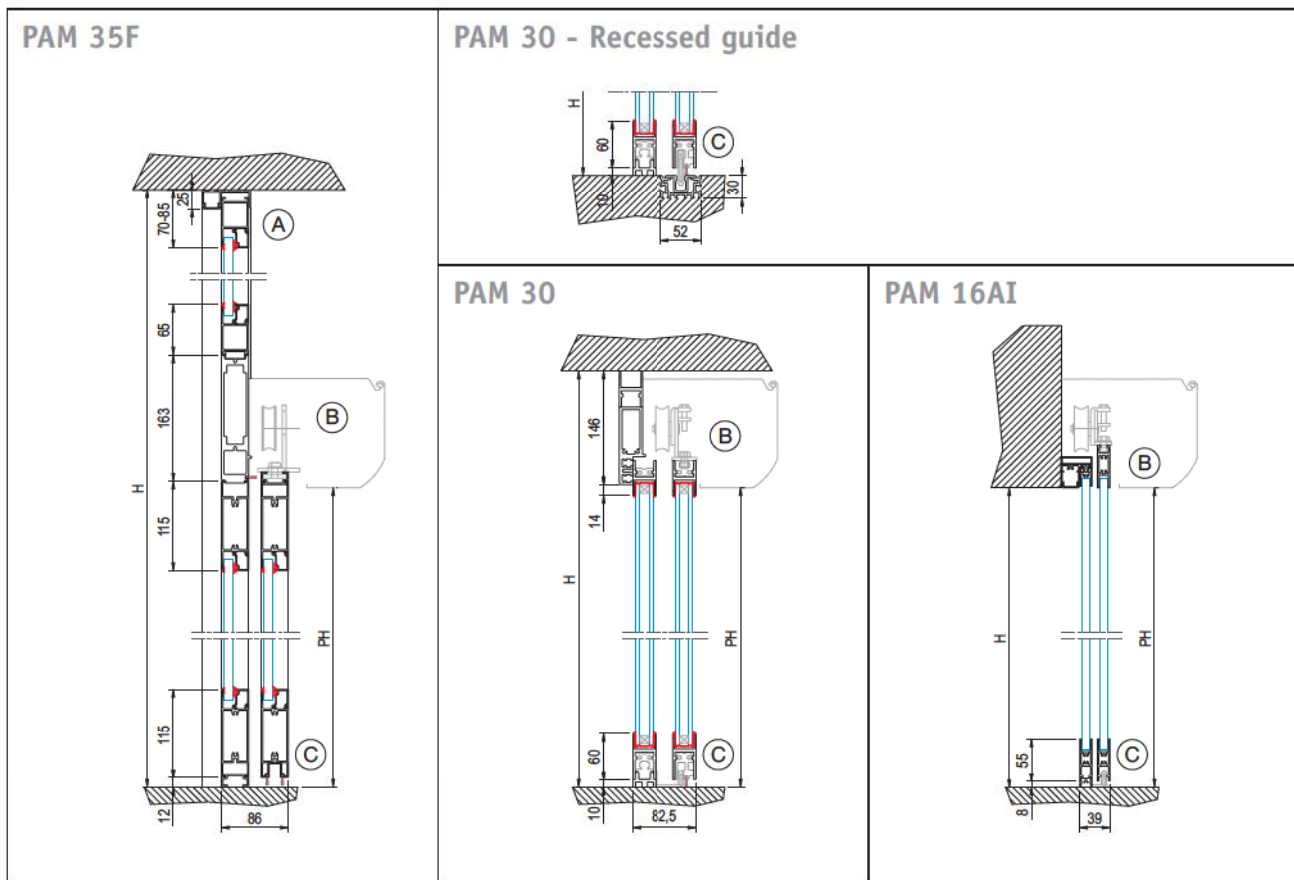

Sliding openings - Applications

Types	DITEC profile series	Dim.	PAM 16AI	PAM 30	PAM 35F
	L = frame opening width H = frame opening height PL = transit opening width PH = transit opening height Casing length 1 panel max. weight	mm mm mm mm mm kg	from 860 to 2500 up to 3000 from 800 to 2440 up to 3000 min. 1700* 80	from 800 to 2500 up to 3000 from 800 to 2500 up to 3000 min. 1700* from 100 to 110**	from 860 to 2500 up to 3000 from 800 to 2440 up to 2970 min. 1650* from 100 to 130**
	L = frame opening width H = frame opening height PL = transit opening width PH = transit opening height Casing length 1 panel max. weight	mm mm mm mm mm kg	from 1680 to 5000 up to 3000 from 800 to 2460 up to 3000 min. 1700* 80	from 1670 to 5000 up to 3000 from 800 to 2465 up to 3000 min. 1700* from 100 to 110**	from 1810 to 5000 up to 3000 from 800 to 2395 up to 2970 min. 1740* from 100 to 130**
	L = frame opening width H = frame opening height PL = transit opening width PH = transit opening height Casing length 2 panels max. weight	mm mm mm mm mm kg	from 1060 to 3200 up to 3000 from 1000 to 3140 up to 3000 min. 2100* from 140 to 160**	from 1000 to 3200 up to 3000 from 1000 to 3200 up to 3000 min. 2100* from 140 to 220**	from 1060 to 3200 up to 3000 from 1000 to 3140 up to 2970 min. 2140* from 140 to 250**
	L = frame opening width H = frame opening height PL = transit opening width PH = transit opening height Casing length 2 panels max. weight	mm mm mm mm mm kg	from 2050 to 6530 up to 3000 from 1000 to 3280 up to 3000 min. 2100* from 140 to 160**	from 2100 to 6600 up to 3000 from 1000 to 3240 up to 3000 min. 2100* from 140 to 220**	from 2370 to 6600 up to 3000 from 1000 to 3050 up to 2970 min. 2310* from 140 to 250**

Key

* maximum length 6600 mm (for actuator TEN = max. 4400 mm)

** according to type of automation selected

Solutions for telescopic sliding door frames

Horizontal sections

Telescopic openings
Examples of types available

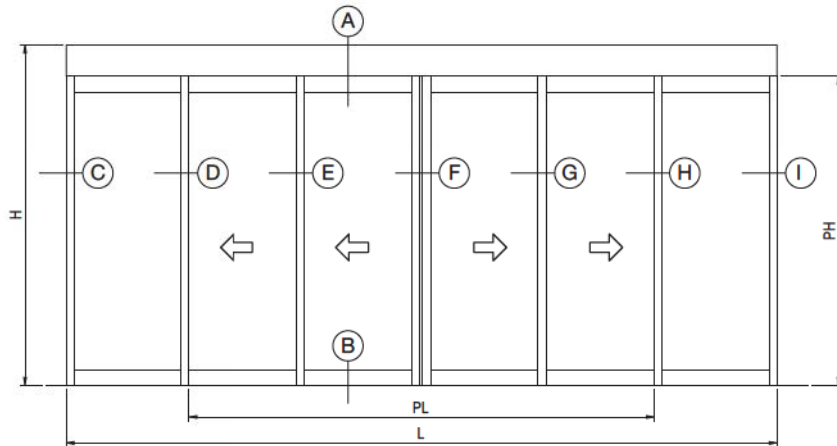
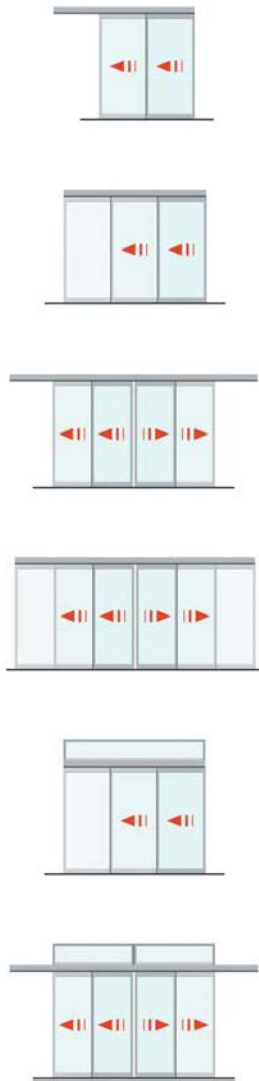

PAM 35F

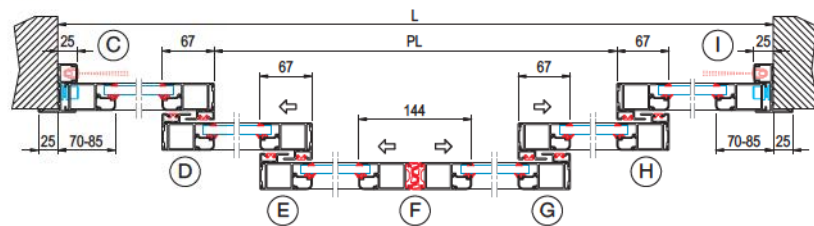

PAM 30

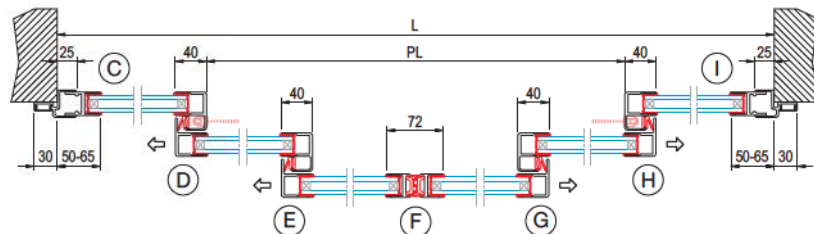

PAM 16AI

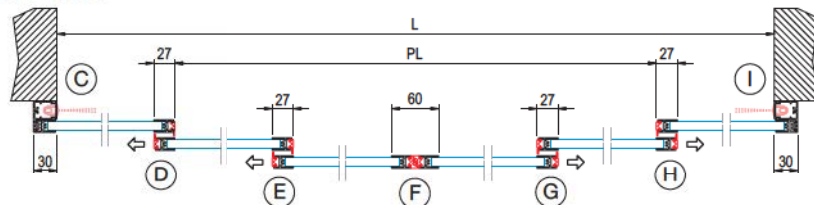

Vertical sections

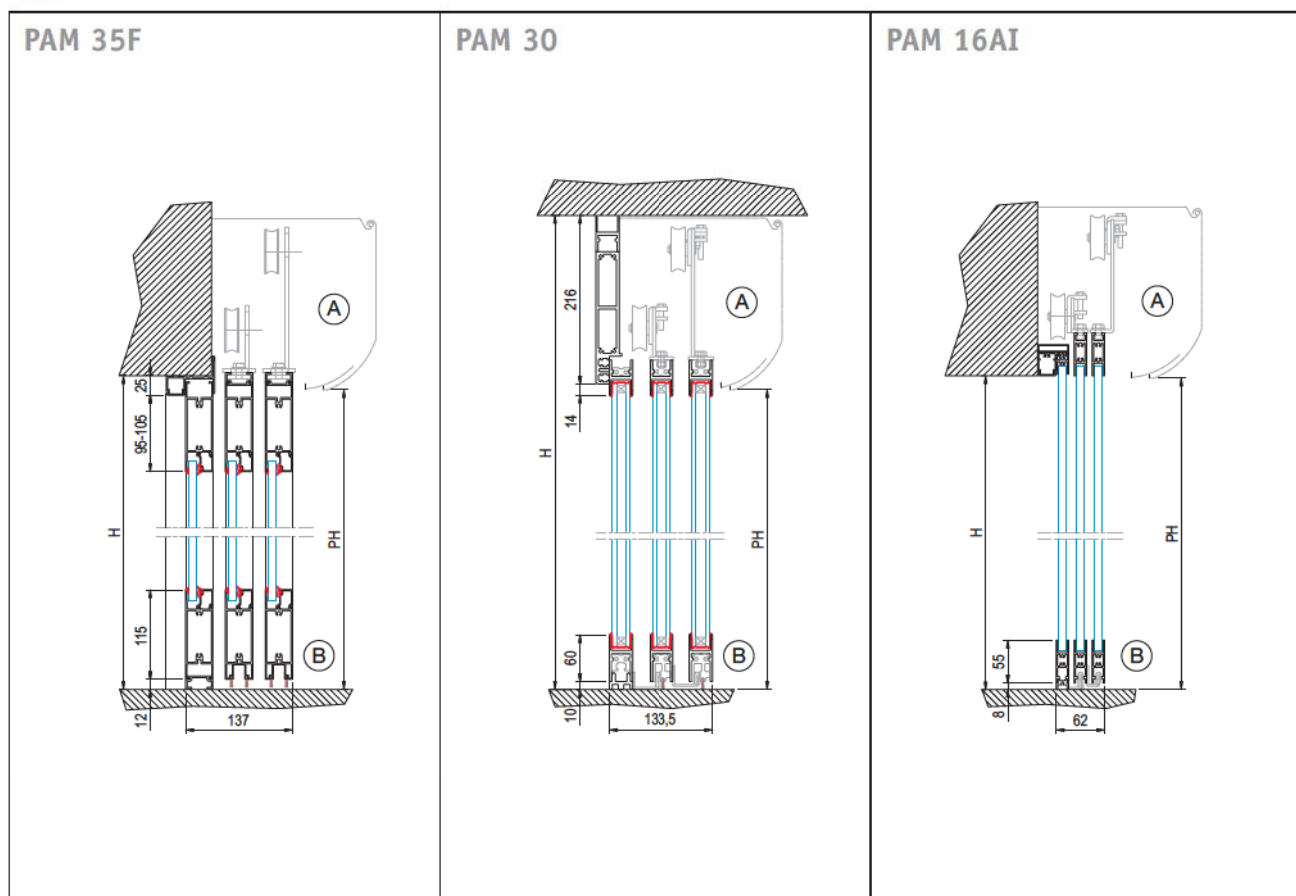

Telescopic openings - Applications

Types	DITEC profile series	Dim.	PAM 16AI	PAM 30	PAM 35F
	L = frame opening width H = frame opening height PL = transit opening width PH = transit opening height Casing length 1+1 panel max. weight	mm mm mm mm mm kg	from 750 to 4300 up to 3000 from 750 to 4300 up to 3000 min. 1200* 160	from 750 to 4300 up to 3000 from 750 to 4300 up to 3000 min. 1200* 180	from 890 to 4300 up to 3000 from 750 to 4160 up to 2970 min. 1350* 180
	L = frame opening width H = frame opening height PL = transit opening width PH = transit opening height Casing length 1+1 panel max. weight	mm mm mm mm mm kg	from 1130 to 6530 up to 3000 from 750 to 4350 up to 3000 min. 1200* 160	from 1180 to 6600 up to 3000 from 750 to 4300 up to 3000 min. 1250* 180	from 1400 to 6600 up to 3000 from 750 to 4170 up to 2970 min. 1320* 180
	L = frame opening width H = frame opening height PL = transit opening width PH = transit opening height Casing length 2+2 panels max. weight	mm mm mm mm mm kg	from 1150 to 4300 up to 3000 from 1150 to 4300 up to 3000 min. 1800* 260	from 1150 to 4300 up to 3000 from 1150 to 4300 up to 3000 min. 1820* 260	from 1400 to 4300 up to 3000 from 1150 to 4060 up to 2970 min. 2050* 260
	L = frame opening width H = frame opening height PL = transit opening width PH = transit opening height Casing length 2+2 panels max. weight	mm mm mm mm mm kg	from 1720 to 6530 up to 3000 from 1150 to 4350 up to 3000 min. 1800* 260	from 1840 to 6600 up to 3000 from 1150 to 4300 up to 3000 min. 1920* 260	from 2240 to 6600 up to 3000 from 1150 to 4060 up to 2970 min. 2280* 260

Key

* maximum length 6600 mm

Sliding solutions with emergency exits

Horizontal sections

Sliding openings with breakout devices

Examples of types available

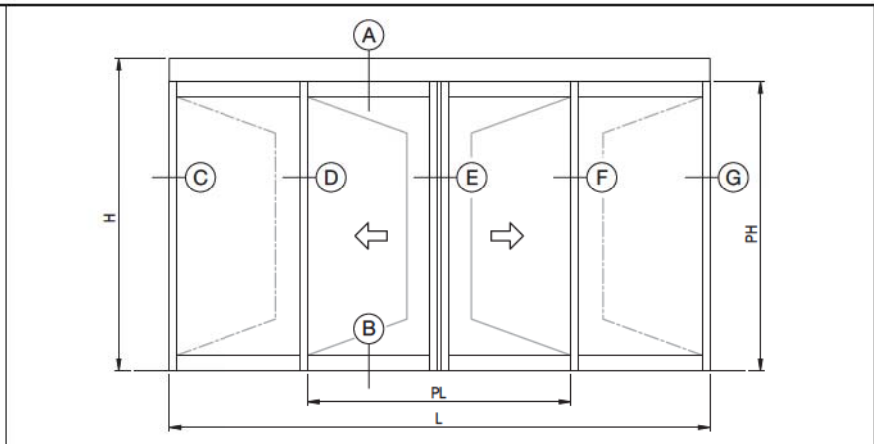
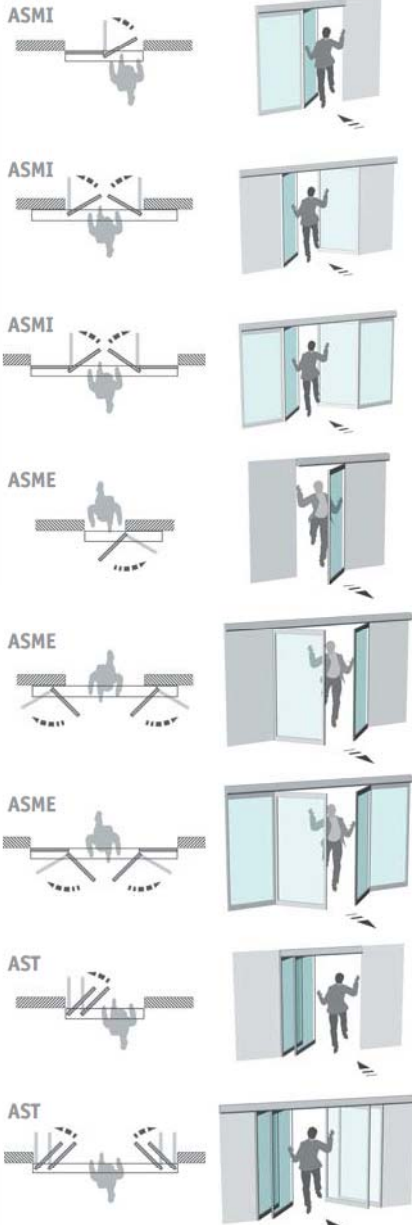

PAM 35F - ASMI

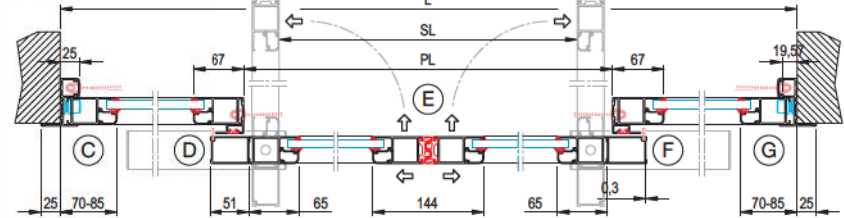

PAM 35F - ASME

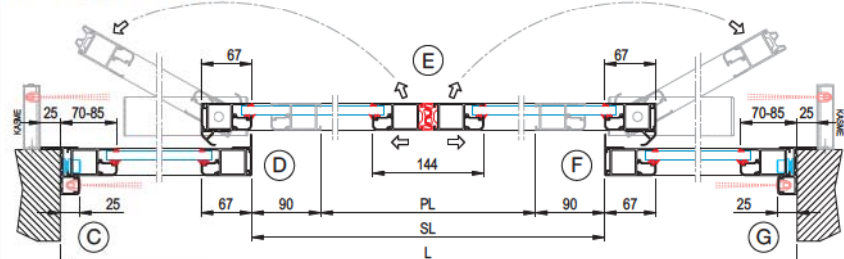



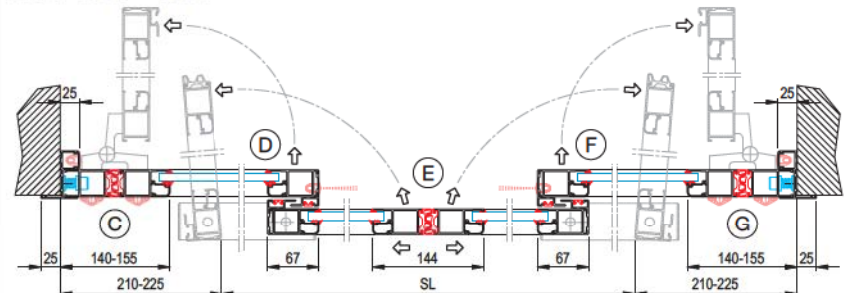

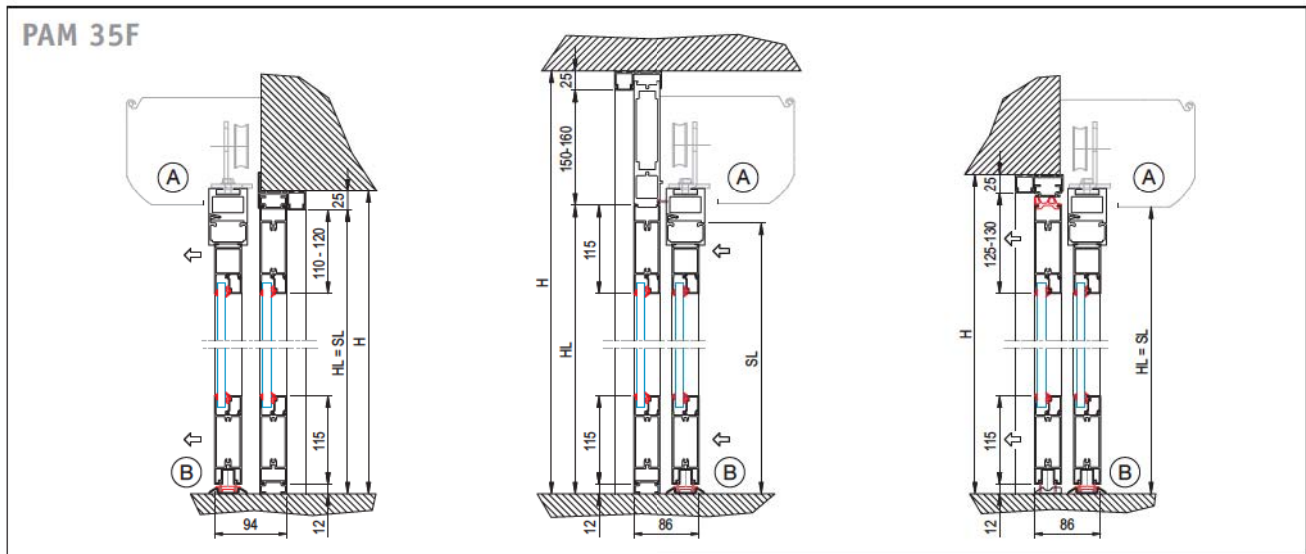

PAM 35F - AST



Vertical sections



Sliding openings with breakout devices - Applications

Types	DITEC PAM 35F profile series Approved systems with anti-panic breakout device for emergency exits	Dim.	ASME	ASMI	AST
					
	L = frame opening width H = frame opening height PL = transit opening width PH = transit opening height SL = Anti-panic exit opening width SH = Anti-panic exit opening height Casing length 1 panel max. weight	mm mm mm mm mm mm mm kg	from 950 to 1400 up to 2400 from 800 to 1245 up to 2375 from 900 to 1345 up to 2375 min. 1850* 100	from 990 to 1470 up to 2400 from 940 to 1420 up to 2375 from 900 to 1380 up to 2350 min. 2000** 100	
	L = frame opening width H = frame opening height PL = transit opening width PH = transit opening height SL = Anti-panic exit opening width SH = Anti-panic exit opening height Casing length 1 panel max. weight Partly fixed side panels max. weight	mm mm mm mm mm mm mm kg kg	from 1770 to 3000 up to 2400 from 800 to 1420 up to 2375 from 900 to 1520 up to 2375 min. 1820* 100 -	from 2040 to 3000 up to 2400 from 940 to 1420 up to 2375 from 900 to 1380 up to 2350 min. 2000** 100 -	from 1850 to 3000 up to 2400 from 800 to 1350 up to 2360 from 1610 to 2765 up to 2360 min. 1800* 100 110
	L = frame opening width H = frame opening height PL = transit opening width PH = transit opening height SL = Anti-panic exit opening width SH = Anti-panic exit opening height Casing length 2 panels max. weight	mm mm mm mm mm mm mm kg	from 1250 to 2740 up to 2400 from 1000 to 2500 up to 2375 from 1200 to 2690 up to 2375 min. 2310* 200	from 1380 to 2880 up to 2400 from 1320 to 2830 up to 2375 from 1230 to 2740 up to 2350 min. 2760** 200	
	L = frame opening width H = frame opening height PL = transit opening width PH = transit opening height SL = Anti-panic exit opening width SH = Anti-panic exit opening height Casing length 2 panels max. weight Partly fixed side panels max. weight	mm mm mm mm mm mm mm kg kg	from 2320 to 6600 up to 2400 from 1000 to 2500 up to 2375 from 1200 to 2690 up to 2375 min. 2330* 200 -	from 2950 to 6600 up to 2400 from 1290 to 2830 up to 2375 from 1200 to 2740 up to 2350 min. 2760** 200 -	from 2820 to 6600 up to 2400 from 1180 to 2680 up to 2360 from 2400 to 6180 up to 2360 min. 2500* 200 110/each
			TÜV approved Cert. No. G321/2	TÜV approved Cert. No. G322	TÜV approved Cert. No. G321/2

Key

- * maximum length 6600 mm (for actuator TEN = max. 4400 mm)
- ** maximum length 6600 mm (actuator TEN not fitted)

Overhead clearances with supporting beam PAM 35F series

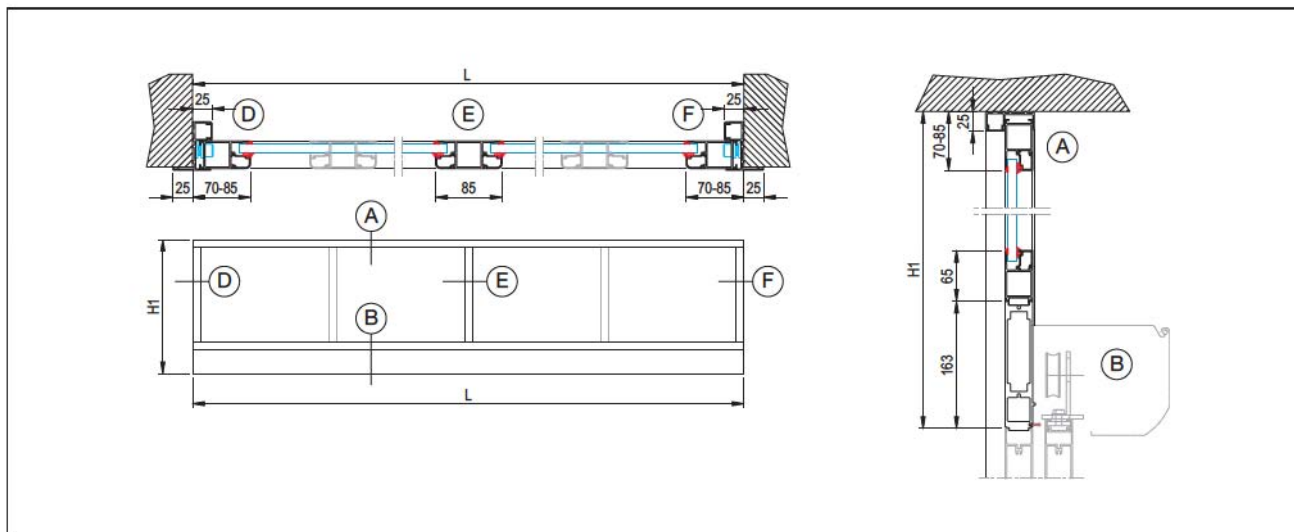

Overhead clearances with supporting beam PAM 35F series - Applications

Types	Overhead clearance made with DITEC PAM 35F series profiles	Dim.	ASME	ASMI	AST
	L = overhead clearance opening width H1 = overhead clearance opening height Overhead clearance max. weight	mm mm kg	from 860 to 6600 up to 2000 350	from 860 to 6600 up to 2000 350	from 860 to 6600 up to 2000 250
The overhead clearance can be made with 1 or more panel-holding frames, on customer's request.					



Glass panels thicknesses

